



analog  
signals



EtherCAT



Bluetooth

VADy

**d · flux multi series** product information

# Multi-Parameter Mass Flow Meter & Mass Flow Controller for Gases

Suitable for most common gases · Flow up to 1400 l/min (Air) · Pressure up to 14 bar a · Options: all stainless, high accuracy, gold plated sensor for Hydrogen

## Maximum flexibility at high speed:

### Multi-parameter mass flow meter & controller for gases

The *d-flux multi series* is a fast and reliable multi-parameter mass flow device for gases with measurement outputs for mass, normalized and volumetric flow, pressure and temperature. The instrument is based on differential pressure measurement over an internal advanced laminar flow element. One of the many advantages of this laminar flow device is the ability to easily switch to a different gas without a loss in accuracy.

The new *d-flux multi series* features:

★ **Meter and Controller**

The unit is available as meter or with a strong integrated control valve as controller

★ **Flow rates up to 1400 l/min**

Rate for air, other gases according to conversion (for instance hydrogen up to 2900 l/min)

★ **Multiple pre-programmed gases**

Up to 15 gases can be pre-programmed in the unit.

★ **3 different sensor options**

The sensor selection is depending on the gas you intend to use. One is economical used for air, nitrogen, oxygen and argon.

★ **State-of-the-art communication**

Advanced Modbus communication & analog output/Optional Profinet or EtherCAT interface (Ethernet IP available soon)

★ **Wide application scope IP54**

Suitable up to 14 bar a and from -20 to 60 °C  
Body in stainless-steel 316L / Protection IP54

★ **Minimum Inlet required**

Compact design, requires no long straight or special in and outlet sections.

★ **Accuracy**

Up to  $\pm 0.3\%$  user full scale and  $\pm 0.5\%$  of measured value (Gas and sensor dependent)

★ **High sample rate and fast response**

Sample rate of 1 ms, updated data every 10 msec and a total response time of 120 msec (controller 2s)

★ **Wireless device access with the free Vögtlin Connect app**

Easy device access and configuration of many parameters with our free Android app (Bluetooth®)

★ **Custom application profiles**

The unit offers up to 15 application profiles which allow the storage of individual application details

★ **Alarm, warning and diagnostic features**

The *d-flux multi series* integrates advanced diagnostics, monitoring and reporting every part of its operation. The information is accessible via Vögtlin Connect app or Modbus

★ **Autotare**

To minimize uncertainty, the *d-flux multi controller* detects with an advanced algorithm when there is no flow and will then automatically zero (tare) the units for optimum performance. For the meter this optimization needs to be performed manually.



**VADy®**

### Introducing Vögtlin Automated Dynamics VADy®

With the *d-flux multi series*, Vögtlin for the first time introduces an automatic real-time calculation of the optimum dynamic range\*.

**Default dynamic range 1 : 100  
1 : 1000 dynamic with VADy® feature  
available**

\*available for meter only



# The Vögtlin Connect App



The Vögtlin Connect app can be used with Android phones and let's you easily and securely (password protected) connect to your *d-flux* device.

Vögtlin Connect is a user friendly configuration software and offers the adjustment of many device parameters:

Bluetooth readable/adjustable variables	Read	Write
Create & edit profiles (set of settings)	✓	✓
Flow range & dynamic range	✓	✓
Filter settings	✓	✓
Alarms and warnings	✓	✓
Analog in/output configuration	✓	✓
Function of push button*	✓	✓
Read current values	✓	
Show Graphs	✓	
Totalizer (read, select, reset)	✓	✓
Node/slave address setting	✓	✓
I/O for external valve on/off	✓	✓
Restart device		✓
Password protection of unit	✓	✓
Factory reset		✓
PID and valve parameters	✓	✓

\* The external push button on the device can be programmed for one of the following functions: Device restart, measurement on/off, warning reset or tare (long press). Activation/Deactivation of Bluetooth® connection (short press).

The app works with Bluetooth® and can be downloaded for free from Google Play store.

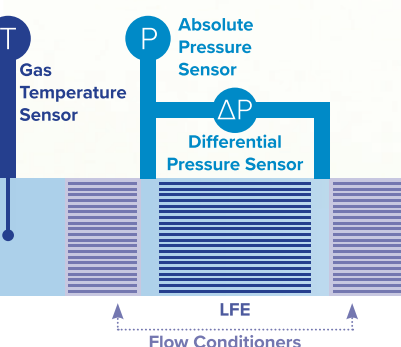

## d-flux multi series operating principle

The *d-flux multi series* uses a **differential pressure measurement over a laminar flow element**. The sensors measure the pressure differential, the absolute pressure and the gas temperature. With this information the internal electronics calculates the mass flow going through the device. A unique advantage of the laminar flowmeter is its **linear relationship between flow rate and developed pressure drop**. By adding a control valve and a PID controller, the meter becomes a mass flow controller. You give a setpoint to initiate a repeatable, stable mass flow. This flow rate is not influenced by changes in pressure and temperature.

## d-flux multi series configurations

The unit is available in 4 ranges (0-500, 0-700, 0-1000 and 0-1400 l/min for air, different ranges apply to other gases). Each range can be reduced by the user by ~30% without any loss in accuracy. The unit is available with a standard economical sensor and an all stainless-steel 316L sensor for corrosive gases and FDA compliance (gold coated for hydrogen). The *d-flux* is an amazingly flexible product, it can handle 15 customer programmable application profiles. Please contact us and discuss any special requirements you have.

**Applications:** Due to the flexibility of the product, the strengths of the product shines in many different industries and applications. The unit is used in the bio/pharma industry, gas consumption measurements, burner control, gas mix systems, testing systems, light semi industry, food industry and energy market.

## Technical data d-flux multi series

### Instrument types



#### d-flux multi meter/controller *essential*

Mass flow meter/controller with analog signals & Modbus interface

#### d-flux multi meter/controller *advanced comms*

Mass flow meter/controller with additional Profinet/EtherCAT interface

Measuring ranges	LFE Type	Range (air)	
<b>Standard ranges</b> (air/user adjustable) <sup>1</sup>	LFE1400	from 0-1000 l/min	to 0-1400 l/min
	LFE1000	from 0-700 l/min	to 0-1000 l/min
	LFE700	from 0-500 l/min	to 0-700 l/min
	LFE500	from 0-350 l/min	to 0-500 l/min

#### Sensor option

Core: Suited for air, nitrogen, oxygen and argon. Mixed wetted materials.  
 Prime: All stainless-steel 316L sensor suitable for all gases. High accuracy optional.  
 Prime H2: Gold coating for Hydrogen (soon available in 2023). High accuracy optional.

Gases (examples only, other gases possible)	Maximum Range	Core	Prime	Prime H2
Air	0-1400 l/min	✓	✓	✓
N <sub>2</sub>	0-1400 l/min	✓	✓	✓
Ar	0-1240 l/min	✓	✓	✓
He	0-1400 l/min		✓	✓
CO <sub>2</sub>	0-740 l/min		✓	✓
CO	0-1390 l/min		✓	✓
H <sub>2</sub>	0-2900 l/min			✓

Above are the default gases pre-programmed for each sensor. More gases can be added as options.<sup>2</sup>

<sup>1</sup> Unless clearly stated, the specified flow ranges are for an equivalent flow of air at 1013.25 mbar a (760 mmHg) and 0°C (32°F). Other common flow, temperature and pressure units can be selected through the Vögtlin Connect app or the digital communication interface. More information available in the d-flux multi operating instructions.

<sup>2</sup> Additional gases or gas mixtures can be added to the above standard list. Maximum you can store up to 15 gases per unit. Stored gases can be replaced by another gas or gas mixture (except for air). Programmed gases/mixtures can be selected through the Vögtlin Connect app or the digital communication interface.

For other gases, gas mixtures and reference conditions please contact the factory. Only suitable for dry and clean gases.

### Profiles

#### Customer defined profiles

Up to 15 user programmable profiles.  
 Profiles are preset configurations where the customer can set the gas, range, dynamics, totalizers, engineering units and reference conditions for up to 15 different applications.

### Performance data

#### Accuracy (after tare at calibration conditions)

A1 Core: ± 0.5% of user full scale ± 1% of measured value.  
 B1 Prime : ± 0.3% of user full scale ± 0.7% of measured value.  
 B2 Prime high accuracy: ± 0.3% of user full scale ± 0.5% of measured value.

Coming soon (Hydrogen applications):

B3 Prime H2: ± 0.3% of user full scale ± 0.7% of measured value.  
 B4 Prime H2 high accuracy : ± 0.3% of user full scale ± 0.5% of measured value.  
 User full scale = ~70...100% standard range.

#### Media

All gases and gas mixtures that are compatible with the selected materials and for which data is available in the NIST refprop database.  
 Contact the factory for more information.

<b>Dynamic range</b>	<p><i>Fixed dynamics:</i> 1:100 for most gases<sup>3</sup>.  <i>VADy® dynamics:</i> up to 1:1000 (available for meter only).  VADy® or a fixed dynamic range can be selected during order process.  This setting can be changed at any time using the Vögtlin Connect app.  <sup>3</sup>The dynamic range is gas and pressure dependent, higher pressures means lower dynamic range.</p>
<b>Response time</b>	<p><i>Meter:</i> Typical 120 msec / <i>Controller:</i> 2000 msec (according to SEMI standard SEMI E17-1011)<sup>4</sup>.  Update time mass flow value: 10 msec / Sensor sample rate: 1 msec.  <sup>4</sup> With optimized filter settings. All filter modes and values can be set through the Vögtlin Connect app or the digital communication interface.</p>
<b>Repeatability</b>	± 0.2% of factory full scale (according to SEMI standard E56-0309).
<b>Longterm stability</b>	Typical < 0.2% of measured value/year after tare.
<b>Power supply</b>	<p><i>Meter:</i> 15-36 Vdc, (200 mA@24Vdc, regulated) / <i>Controller:</i> 24 Vdc ±10%, (2000mA@24Vdc, regulated).  Power in through M8-4P connection or optionally through D-sub connection  (ripple should not exceed 100 mV peak-to-peak). We recommend that the body of this unit is properly connected to ground.</p>
<b>Operation pressure</b>	1 to 14 bar a.
<b>Temperature (environment/gas)</b>	-20 to +60 °C (-4 to 140 °F) .
<b>Humidity gas</b>	0-95% Rh (non-condensing).
<b>Pressure sensitivity</b>	<p>Prime and Prime H2 sensor: &lt;0.05% factory full scale per bar (typical air).  Core sensor: &lt;0.08% of factory full scale + 0.1% of measured value per bar (typical air).</p>
<b>Temperature sensitivity</b>	<0.02% factory full scale (maximum flow range of the device) per 1°C of inlet gas temperature @ 7 bar a pressure.
<b>Accuracy temperature</b>	Typically ± 0.5 °C (not certified).
<b>Accuracy absolute pressure</b>	<0.5% of measured value (not certified).
<b>Warm-up time</b>	<2 sec for full accuracy.
<b>Materials</b>	
<b>Wetted parts</b>	<p>Elastomers: available now : FKM, EPDM (Meter only). EPDM (Controller, coming in 2023), FFKM Valve seat (coming in 2023). Full FFKM version (on request).  Body: Stainless-steel 316L (1.4404).  Valve (controller): 316 (1.4401), 416 (1.4005), 430F (1.4104).  Inlet filter: Stainless-steel 316 (1.4401), fastening stainless-steel (1.4122) or equivalent.  A1 core sensor: Stainless-steel 316Ti (1.4571), silicon, gold, glass, silicone encapsulation, PBT. 30GF, ceramics. B1 Prime sensor: Stainless-steel 316L (1.4404).  B2 Prime H2 sensor: Stainless-steel 316L (1.4404) with gold coating.</p>
<b>Electronic housing</b>	Powder coated stainless steel.
<b>Integrated inlet filter</b>	50 Micron stainless-steel 316 (1.4401) filter/not customer replaceable/fastener material stainless-steel (1.4122) or equivalent.
<b>Wetted part surface roughness</b>	1.6 Ra µm or better (contact factory for lower Ra values).
<b>Integration &amp; Installation</b>	
<b>Output signals analog</b>	<p>Linear 4–20 mA or customer defined (max 20 mA) user selectable.  Linear 0–5 VDC or 0-10 VDC or customer defined (max 10 Volt) user selectable  mA output: 740 ohms maximum load resistance.  Volt output: 1000 ohms minimum load resistance.  All analog outputs are galvanically separated and protected.  If used with analog signals add 0.2% of factory full scale to the uncertainty.</p>
<b>Setpoint signals analog</b>	<p>Linear 4–20 mA or customer defined (max 20 mA) user selectable.  Linear 0–5 VDC or 0-10 VDC or customer defined (max 10 Volt) user selectable.</p>
<b>Output signals digital</b>	<p>RS-485 (Modbus RTU 2-wire).  The Modbus address can be set with 2 rotating switches on the outside of the housing.  All Modbus settings can be set through the Vögtlin Connect app.</p>
<b>Optional digital communication</b>	<p>Dual Port RJ45 with integrated switch (easy to daisy chain).  RJ45 LEDs indicating link and activity on the network / Ethernet speed: maximum 100 Mbit.  Profinet: Profinet IO specification v2.33 / Profinet IO devices conformance class B (RT) / Endianness: conform Siemens S7 (big).  EtherCAT: IEC standard IEC61158 / Endianness: little.  Ethernet IP™ will be available end of 2023.</p>
<b>Configuration interface</b>	Bluetooth 4.0 (free Vögtlin Connect app available from Google Play store).
<b>Output I/O mosfet</b>	<p>On/off for external shut-off valve or alarm available through M8-4P connector.  Contact type: mosfet transistor.  Maximum voltage: 36 Vdc, Max current 500 mA (Polyfuse protected).</p>

<b>Electrical connection</b>	9 pin D-sub male (power and signals) M8-4P Ethernet IP™ connector (open collector output + power). Optional 2 x RJ45 (EtherCAT / Profinet).
<b>Process connection</b>	1" BSPP female (G1"). Optional: ½" BSPP, 1" Compression or Tri-clamp 50.5mm flange size (ISO) (see accessories page).
<b>Inlet section</b>	None required if our standard inlet filter/conditioner is installed. Without filter/conditioner a 10 D straight inlet is recommended. The inlet filter can be deselected at time of order.



<b>Pressure drop</b>	<i>Meter:</i> Standard 400 mbar at factory full scale air venting to atmosphere (with filter/conditioner). Optional: 325 mbar at factory full scale air venting to atmosphere (without filter/conditioner). Pressure drop is dependent on operating pressure (higher pressure = lower pressure drop). For more information please refer to your sales partner. <i>Controller:</i> Min. pressure difference required for 1400 l/min (air) < 3 bar. Contact your sales partner for other pressure drop requirements.
<b>Mounting orientation</b>	All orientations are possible
<b>Weight</b>	<i>Meter:</i> 3.7 kg / <i>Controller:</i> 8.7 kg (excluding ethernet and fittings)
<b>Safety</b>	
<b>Test pressure after production</b>	21 bar a
<b>Maximum overpressure sensor</b>	Core sensor: 28 bar a, Prime and Prime H2 sensor 90 bar a
<b>Burst pressure</b>	<i>Meter:</i> 100 bar a / <i>Controller:</i> 70 bar a
<b>Leak rate</b>	< 1 x 10 <sup>-6</sup> mbar l/s He
<b>Ingress protection class</b>	IP54 if IP54-D-sub is used (see accessories page). For optional EtherCAT/Profinet: IP40
<b>Certifications</b>	
<b>EMC</b>	IEC/EN 61326-1, IEC/EN 61000-6-2/4
<b>ATEX certification</b>	None
<b>Material certificates</b>	Available soon, for meter only.
<b>FDA compliance</b>	Available soon, for meter only.
<b>PED</b>	Fully compliant. Since the unit has 1" process connection, complies with the SEP as defined in article 4, paragraph 3 of the Pressure Equipment Directive (PED) (2014/68/EU).
<b>RoHS/REACH</b>	All components comply with Directive 2002/95/EC (RoHS) and the REACH guidelines.
<b>Warranty</b>	3 years, except when using certain corrosive / dangerous gases (HCL, CL2, F2, H2S, SO2)

*Technical specifications and dimensions subject to change without notice.*

## Accessories <d-flux multi series>

### Power, plugs and cables



#### IP54-D9-sub connector

This plug connects to the male D-sub on top of the d-flux unit to connect the signals and power. With this plug installed and the cap on the DIN M8 connector the integrity rating of this unit is IP54. Available as plug only (solder connections inside) or with 2 meter cable with fly leads. Maximum current 2 amp.

Art-N° 328-2093 IP54-D9-sub connector (IP54 rated, 9 solder connections, no cable)  
 Art-N° 328-2094 IP54-D9-sub connector (IP54 rated with 2 meter cable and fly leads (9))



#### IP20-D9-sub connector

Available as plug only or with 2 meter cable (for indoor IP20 applications only)

Art-N° 328-2102 IP20-D9-sub connector (IP20 rated, 9 solder connections, no cable)  
 Art-N° 328-2103 IP20-D9-sub connector (IP20 rated with 2 meter cable and fly leads (9))



#### IP40-Power supply

In: 100-240 Vac / Out: 24 Vdc, 2.2A with M8-4pin connector  
 Not suitable for IP54 applications, for indoor IP40 applications only. Suitable for meters and controllers. Used to configure the d-flux on your desktop with the Vögtlin Connect app

Art-N° 328-2361 Table top power supply (EU plug)  
 Art-N° 328-2362 Table top power supply (US plug)  
 Art-N° 328-2363 Table top power supply (GB plug)  
 Art-N° 328-2364 Table top power supply (AU plug)  
 Art-N° 328-2365 Table top power supply (CN plug)



#### IP20-RS485 to USB

A simple way to connect your d-flux over Modbus to your PC  
 Consisting of 1) RS485 to USB converter (no external power required for converter), 2) a USB-A (version 2.0) connection to your PC and 3) a 9 pin D-sub female connector to the d-flux / Total cable length 3 meters.  
 USB 2.0-B female to 1 x 9 pin serial RS422/485 male  
 Chipset: FT232HL, SP3078EE, Dimension: 80 x 72 x 23 (LxWxH)  
 Power supply for the d-flux needs to be purchased separately – not included in this kit.

Art-N° 328-2112



#### IP54-M8 plug

Available as plug only or with 2 meter cable. M8-4pin plugs are suitable for IP54 applications. Maximum current 4 Amp.

Art-N° 328-2096 IP54-M8 connector (4 Pin straight female with screw terminals and cable gland)  
 Art-N° 328-2097 IP54-M8 connector as above but with 2 meter cable with fly leads



#### IP54-M8 cap

Cap to seal off M8 connection if not used (required for IP54 protection). Supplied one with every unit. Only required when IP54 protection is lost or damaged

Art-N° 632-1221 IP54-M8 cap (to close off/open not used M8 connector)

### Fittings



#### 1" Compression fitting

Stainless-steel Compression Tube Fitting, Male Connector, 1". Tube OD x 1" BSPP tread  
 Male ISO Parallel Thread / Material stainless-steel 316 (1.4401) including O-rings  
 Optional 3.1 Certificate upon request when order is placed

Art-N° 328-1254 FKM  
 Art-N° 328-1255 EPDM



#### DN50 Tri-clamp

Tri-clamp connection 50.5mm flange (ISO), to 1" BSPP tread  
 Material 316L (1.4404) including O-rings

Art-N° 328-1426 FKM  
 Art-N° 328-1427 EPDM



#### Reducer 1" BSPP to 1/2" female BSPP

Reduced process connections from 1" BSPP male tread to 1/2" BSPP female  
 Material 316Ti (1.4571) including seal rings

Art-N° 328-1257 FKM (Contact factory for other elastomers)

## Configuration matrix d-flux multi series

<b>Functionality</b>	<input type="checkbox"/> d-flux multi meter																											
	<input type="checkbox"/> d-flux multi controller																											
<b>Gas(es) to measure</b>	<input type="text"/>																											
<b>Temperature of the gas (range from/to)</b>	<input type="text"/>																											
<b>Flow range / flow units (f.i. l/min)</b>	<input type="text"/>																											
<b>Sensor selection</b>	<input type="checkbox"/> Core sensor for Air, N2 and Argon only																											
	<input type="checkbox"/> Prime sensor for most gases, all 316 <input type="checkbox"/> High accuracy																											
	<input type="checkbox"/> Prime H2 sensor with gold coating for H2 applications <input type="checkbox"/> High accuracy																											
	<input type="checkbox"/> VADy® (max. 1:1000) customer adjustable (available for meter only)																											
<b>Dynamic range</b>	<input type="checkbox"/> Fixed dynamics* (default 1:100) See configurator to determine dynamics for process conditions																											
	<input type="checkbox"/> VADy® (max. 1:1000) customer adjustable (available for meter only)																											
<b>Pressure</b> (please state absolute or gauge)	Pressure inlet (P1) <input type="text"/> Pressure outlet (P2) <input type="text"/>																											
<b>Control valve</b>	The valve type, orifice, springs and position (inlet or outlet) will be determine by the factory																											
<b>Body material</b>	Stainless-steel 316L (1.4404)																											
<b>O-rings</b>	<input type="checkbox"/> FKM <input type="checkbox"/> EPDM <input type="checkbox"/> FFKM (Kalrez® 220)																											
	<input type="checkbox"/> FKM <input type="checkbox"/> EPDM <input type="checkbox"/> FFKM (Kalrez® 220)																											
	<input type="checkbox"/> FKM <input type="checkbox"/> EPDM <input type="checkbox"/> FFKM (Kalrez® 220)																											
<b>Analog Signals</b>	<table border="0"> <tr> <td></td> <td style="text-align: center;"><i>Output signals</i></td> <td style="text-align: center;"><i>Setpoint signal (controller only)</i></td> </tr> <tr> <td><input type="checkbox"/></td> <td>4-20 mA + 0-5V*</td> <td><input type="checkbox"/> 4-20 mA*</td> </tr> <tr> <td><input type="checkbox"/></td> <td>4-20 mA + 1-5V</td> <td><input type="checkbox"/> 0-20 mA</td> </tr> <tr> <td><input type="checkbox"/></td> <td>4-20 mA + 0-10V</td> <td><input type="checkbox"/> 0-5 Vdc</td> </tr> <tr> <td><input type="checkbox"/></td> <td>4-20 mA + 2-10V</td> <td><input type="checkbox"/> 1-5 Vdc</td> </tr> <tr> <td><input type="checkbox"/></td> <td>0-20 mA + 0-5V</td> <td><input type="checkbox"/> 0-10 Vdc</td> </tr> <tr> <td><input type="checkbox"/></td> <td>0-20 mA + 1-5V</td> <td><input type="checkbox"/> 2-10 Vdc</td> </tr> <tr> <td><input type="checkbox"/></td> <td>0-20 mA + 0-10V</td> <td></td> </tr> <tr> <td><input type="checkbox"/></td> <td>0-20 mA + 2-10V</td> <td></td> </tr> </table>		<i>Output signals</i>	<i>Setpoint signal (controller only)</i>	<input type="checkbox"/>	4-20 mA + 0-5V*	<input type="checkbox"/> 4-20 mA*	<input type="checkbox"/>	4-20 mA + 1-5V	<input type="checkbox"/> 0-20 mA	<input type="checkbox"/>	4-20 mA + 0-10V	<input type="checkbox"/> 0-5 Vdc	<input type="checkbox"/>	4-20 mA + 2-10V	<input type="checkbox"/> 1-5 Vdc	<input type="checkbox"/>	0-20 mA + 0-5V	<input type="checkbox"/> 0-10 Vdc	<input type="checkbox"/>	0-20 mA + 1-5V	<input type="checkbox"/> 2-10 Vdc	<input type="checkbox"/>	0-20 mA + 0-10V		<input type="checkbox"/>	0-20 mA + 2-10V	
		<i>Output signals</i>	<i>Setpoint signal (controller only)</i>																									
<input type="checkbox"/>	4-20 mA + 0-5V*	<input type="checkbox"/> 4-20 mA*																										
<input type="checkbox"/>	4-20 mA + 1-5V	<input type="checkbox"/> 0-20 mA																										
<input type="checkbox"/>	4-20 mA + 0-10V	<input type="checkbox"/> 0-5 Vdc																										
<input type="checkbox"/>	4-20 mA + 2-10V	<input type="checkbox"/> 1-5 Vdc																										
<input type="checkbox"/>	0-20 mA + 0-5V	<input type="checkbox"/> 0-10 Vdc																										
<input type="checkbox"/>	0-20 mA + 1-5V	<input type="checkbox"/> 2-10 Vdc																										
<input type="checkbox"/>	0-20 mA + 0-10V																											
<input type="checkbox"/>	0-20 mA + 2-10V																											
For the output there is one Vdc and one separate mA signal. For the setpoint there is only one analog input signal. These signals can be adapted through the Vogtlin Connect app.																												
<b>Digital Communication</b>	<input type="checkbox"/> Modbus communication*																											
	<input type="checkbox"/> Modbus & EtherCAT (unit becomes IP40)																											
	<input type="checkbox"/> Modbus & Profinet (unit becomes IP40)																											
	<input type="checkbox"/> None (1" BSPP female connection)*																											
<b>Fittings</b>	<input type="checkbox"/> None (1" BSPP female connection)*																											
	<input type="checkbox"/> 1" Compression fitting stainless-steel 316L (1.4404)																											
	<input type="checkbox"/> Tri-clamp 50.5 mm flange (ISO) stainless-steel 316L (1.4404)																											
	<input type="checkbox"/> Reducer to 1/2" BSPP female stainless-steel 316L (1.4571)																											
<b>Calibration Certificate</b>	<input type="checkbox"/> Factory calibration 5 points*																											
	<input type="checkbox"/> Factory calibration protocol 20 points																											

Contact the factory for available certifications and approvals

\*default

## Dimensions & electrical connections d-flux multi series

Dimensions in mm [values in brackets are inch sizes] / Depending on the configuration, the valve can be on right or left side of the body

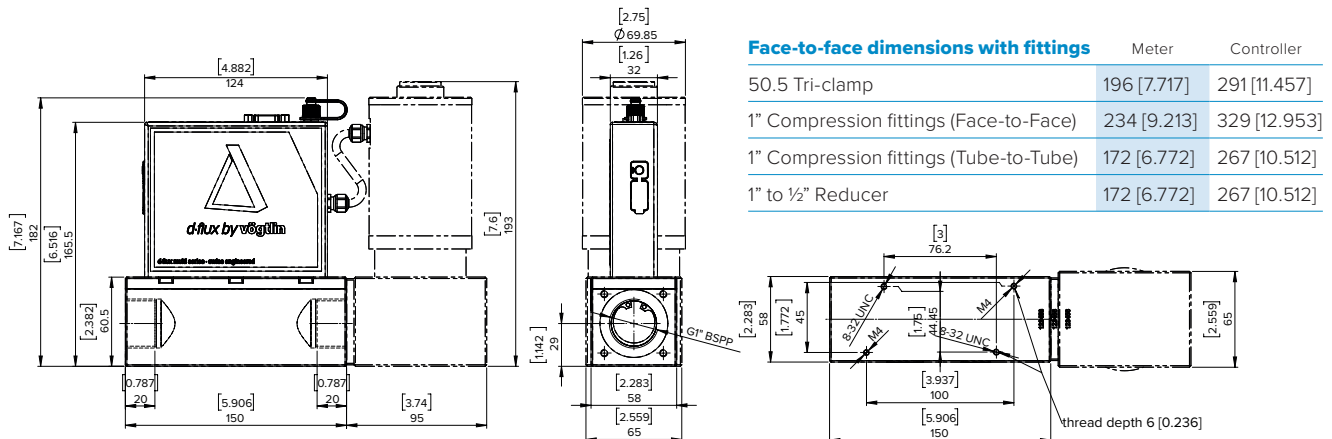



# Worldwide TASI Flow Network



Vögtlin Sales & Service Hub North America:

**Sierra Instruments**

5 Harris Court, Building L  
Monterey, CA 93940, USA

Phone +1 800 866 0200  
Fax +1 831 373 4402

sales@sierrainstruments.com  
[www.sierrainstruments.com](http://www.sierrainstruments.com)

International Headquarter:

**Vögtlin Instruments GmbH**

St. Jakob-Strasse 84  
4132 Muttenz, Switzerland

Phone +41 61 756 63 00  
Fax +41 61 756 63 01

info@voegtlin.com  
[www.voegtlin.com](http://www.voegtlin.com)

Vögtlin Sales & Service Hub China:

**KEM flow technology (Beijing) Co., Ltd.**

Rm. 906, Block C, Ruiipu Office Bldg,  
No. 15, HongJunYingNan Road,  
Chaoyang District, Beijing 100012, China

Phone +86 10 849 29567

info@kem-kueppers.cn  
[www.voegtlin.cn](http://www.voegtlin.cn)

Find your local Vögtlin sales partner on our website:

[www.voegtlin.com](http://www.voegtlin.com)



**Vögtlin Instruments GmbH – gas flow technology**

St. Jakob-Strasse 84 | 4132 Muttenz (Switzerland)

Phone +41 61 756 63 00 | Fax +41 61 756 63 01

[www.voegtlin.com](http://www.voegtlin.com) | [info@voegtlin.com](mailto:info@voegtlin.com)

